



SAFETY GUARD FOR PPB15S PRESS

MODEL NO: PPBSG

Thank you for purchasing a Sealey product. Manufactured to a high standard, this product will, if used according to these instructions, and properly maintained, give you years of trouble free performance.

IMPORTANT: PLEASE READ THESE INSTRUCTIONS CAREFULLY. NOTE THE SAFE OPERATIONAL REQUIREMENTS, WARNINGS & CAUTIONS. USE THE PRODUCT CORRECTLY AND WITH CARE FOR THE PURPOSE FOR WHICH IT IS INTENDED. FAILURE TO DO SO MAY CAUSE DAMAGE AND/OR PERSONAL INJURY AND WILL INVALIDATE THE WARRANTY. KEEP THESE INSTRUCTIONS SAFE FOR FUTURE USE.



Refer to instructions

1. SAFETY

- ✓ Familiarise yourself with the applications, limitations and hazards peculiar to the safety guard.
- ✓ Maintain the safety guard in good condition.
- ✓ Replace or repair damaged parts. Use recommended parts only. Unauthorised parts may be dangerous and will invalidate the warranty.
- ✓ Keep the safety guard clean for best and safest performance.
- ✓ Ensure the safety guard is correctly attached before operating the press.
- ✓ Ensure that all fittings are tight before each use.
- ✓ Remove ill fitting clothing. Remove ties, watches, rings, loose jewellery and contain long hair.
- ✓ Keep hands and body clear of the safety guard when operating the press.
- ✓ Maintain correct balance and footing. Ensure the floor is not slippery and wear non-slip footwear.
- ✓ Keep children and unauthorised persons away from the working area.
- × **DO NOT** use the guard for purposes other than those it was designed for.
- WARNING!** Always, refer to the safety instructions provided in your presses instruction manual.
- WARNING!** The warnings, cautions and instructions in this manual cannot cover all possible conditions and situations that may occur. It must be understood by the operator that common sense and caution are factors which cannot be built into this product, but must be applied by the operator.

2. INTRODUCTION

Lightweight steel frame with tough 4.8mm Polycarbonate screen. Adjustable guard protects the user and/or passer by from being injured if workpiece is accidentally dislodged under load. Bolts onto either side of the table and features four height increments, allowing the workpiece to be placed onto table with no obstruction. One-way spring loaded locking clips then allow the guard to be pulled up quickly and snap straight into position for full protection.

3. SPECIFICATION

Model No:PPBSG
Application(s):PPB15S

4. ASSEMBLY

Unpack the product and check contents. Should there be any damaged or missing parts contact your supplier immediately.

Refer to attached parts list.

4.1. ATTACH HANDLE GRIP

- 4.1.1. Remove protective film from PC board (#1).
- 4.1.2. Position handle grip (#21) onto PC board (#1) and secure with flat washer M5 (#3) and machine screw pan head M5 x 10 (#2).

4.2. ATTACH LOCKING KNOB

- 4.2.1. Screw locking knob (#7) into threaded insert located at the top, left hand side of the frame (#4).

5. OPERATION

5.1. ATTACH THE SAFETY GUARD

- 5.1.1. Lift up the safety guard by taking hold of the side grips (#11).
NOTE: Handle grip (#21) to be facing outwards and at it's lowest position (fig 2).
- 5.1.2. Insert the T-shape screws (#17) into the key holes located on the front of the press' working table (figs 1 & 3).
 WARNING! Ensure that both the T-shape screws are fully located into the key slots. Failure to do so may result in the safety guard becoming detached from the press causing possible personal injury and damage to the safety guard.

5.2. INSERTING THE WORKPIECE

- 5.2.1. Holding the handle grip (#21) turn the locking knob (#7) counter clockwise (fig 2) and raise the safety guard PC board (#1) fully to the top (fig 2).
- 5.2.2. Lock the PC board (#1) into place by turning the locking knob (#7) clockwise (fig 2). **DO NOT** over tighten.
- 5.2.3. Insert the workpiece onto the press' working table.

- 5.2.4. Holding the handle grip (#21) unlock the locking knob (#7) by turning counter clockwise (fig 2) and lower the PC board (#1) fully down.
- 5.2.5. Lock the PC board (#1) into place by turning the locking knob (#7) clockwise (fig 2). **DO NOT** over tighten.
- 5.2.6. When the press operation is complete raise the PC board (#1). See section 5.2.1.
- 5.2.7. Remove the workpiece.
- 5.2.8. Lower the PC board (#1). See section 5.2.4.
- 5.2.9. Lock the PC board (#1) See section 5.2.5.
- 5.3. **REMOVING THE SAFETY GUARD**
- 5.4. **NOTE:** Ensure that the PC board (#1) is locked in place and is at it's lowest position.
- 5.4.1. Remove the safety guard by taking hold of the side grips (#11) and raise slightly.
- 5.4.2. Align the T shaped screws (#17) with the larger hole of the key slot and pull the safety guard away and place in a secure location.

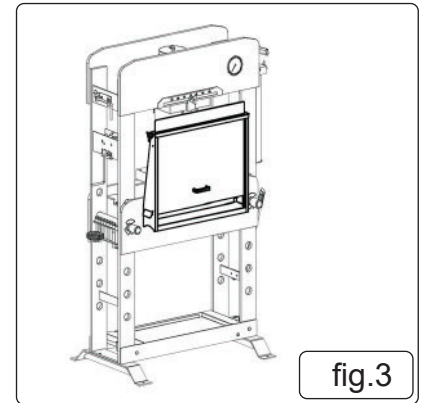
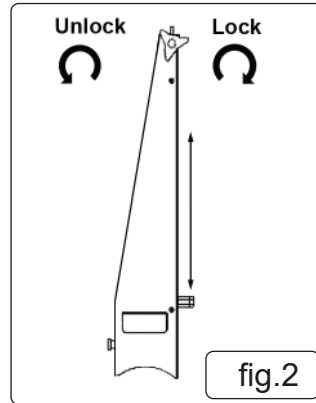
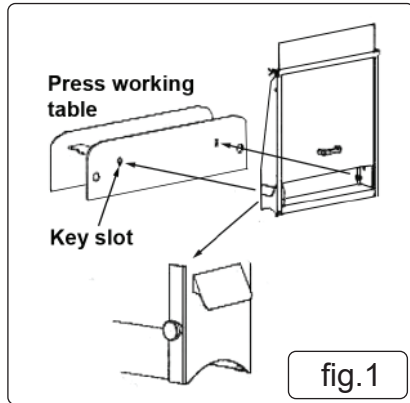

6. MAINTENANCE

- 6.1. Clean with a damp cloth.
 x **DO NOT** use solvents.



ENVIRONMENT PROTECTION

Recycle unwanted materials instead of disposing of them as waste. All tools, accessories and packaging should be sorted, taken to a recycling centre and disposed of in a manner which is compatible with the environment. When the product becomes completely unserviceable and requires disposal, drain any fluids (if applicable) into approved containers and dispose of the product and fluids according to local regulations.

Note: It is our policy to continually improve products and as such we reserve the right to alter data, specifications and component parts without prior notice.

Important: No Liability is accepted for incorrect use of this product.

Warranty: Guarantee is 24 months from purchase date, proof of which is required for any claim.

Sealey Group, Kempson Way, Suffolk Business Park, Bury St Edmunds, Suffolk. IP32 7AR



01284 757500



01284 703534



sales@sealey.co.uk



www.sealey.co.uk